

Bowl-Tronics Enterprises Incorporated

Address: 1115 Sherwood Ave.

Elgin IL. 60120

Website: www.bowl-tronics.com

E-mail: rick@bowl-tronics.com

Phone: 847-741-4500

Ball Lift Motor Control Box (BL120-240)

Ball Lift Motor Control Box Theory

This ball lift motor control box is designed to replace the existing Brunswick ball lift box or similar ball lift box. On the inside cover of the (BL120-240) there will be a schematic on how to wire the (BL120-240), it will also be on the back of this page. From the machine 24 VAC supplies voltage to the solid-state control circuit, this closes the circuit to start your ball lift and hand dryer motor running.

Installation Instructions

Remember to remove power before performing any installation!!

First, start by removing the old ball lift box. Next, you will utilize the main power cable, ball lift motor cable, hand dryer cable and the two sets of low voltage 24 VAC wires from the machine. Start by installing your main power connection to the new (BL120-240) box. Next, install the ball lift motor cable to the (BL120-240) box. The hand dryer output will have a 5 ft black SJOW cable which will splice into your hand dryer motor. View the schematic to help wire up all the connections to the (BL120-240) box. Finally, hook up the 24 VAC low voltage wires to the (BL120-240) box via the quick disconnect bullet connectors.

For repair visit: www.bowl-tronics.com/service

Fill out our service request form and ship to the address that is shown.

Notes:

Ball Lift Motor Control Box Schematic

BALL LIFT MOTOR CONTROL CHASSIS 120 VAC INPUT

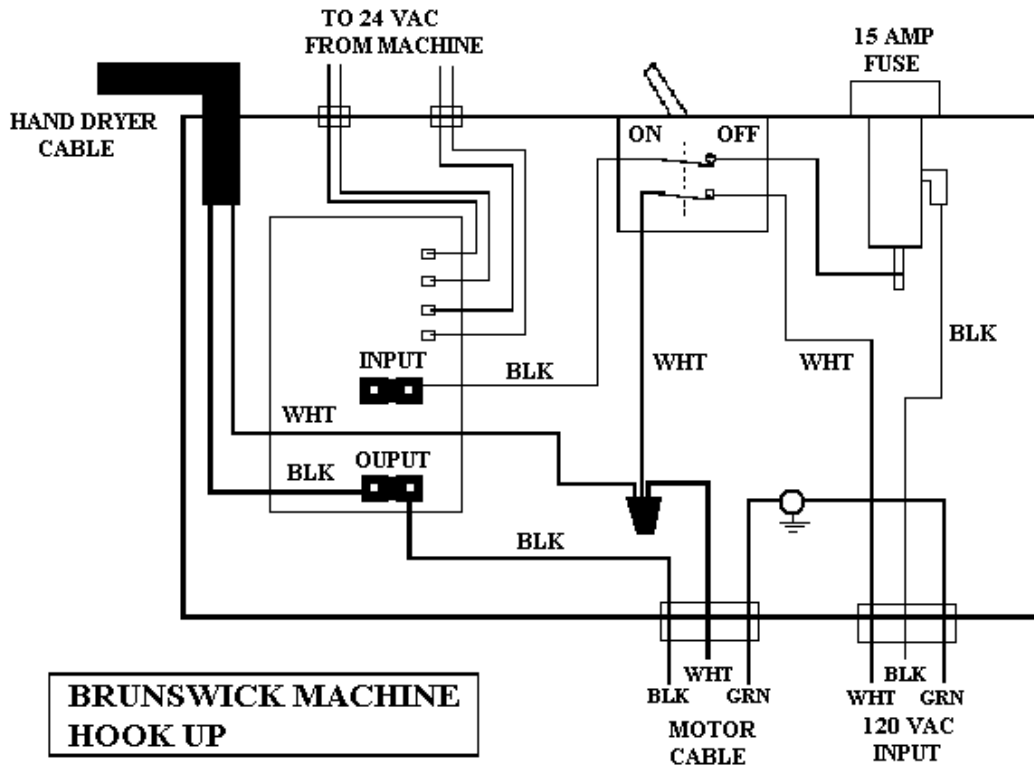

BALL LIFT MOTOR CONTROL CHASSIS 220 VAC INPUT

