

Bowl-Tronics Enterprises Incorporated

Address: 1115 Sherwood Ave.
Elgin IL. 60120
Website: www.bowl-tronics.com
E-mail: rick@bowl-tronics.com

Phone: 847-741-4500

Ball Lift Motor Control Kit (BL-KIT)

Ball Lift Motor Control Kit Theory

This ball lift motor control kit is designed to replace the existing Brunswick ball lift relays or similar ball lift relays, while still using your existing ball lift box. Supplied with the (BL-KIT) there will be a schematic on how to wire the (BL-KIT) into your box. The schematic should be placed on the inside cover of your existing box for future reference. The schematic will also be on the back of this page. From the machine 24 VAC supplies voltage to the solid-state control circuit, this closes the circuit to start your ball lift and hand dryer motor running.

Installation Instructions

Remember to remove power before performing any installation!!

First, start by removing the old ball lift relays. Carefully remove the (BL-KIT) pc from the mounting plate. Take the mounting plate to the ball lift box and align the screws on the bottom of the plate with the holes in the box where the relays use to be. Adjust the screws as necessary and tighten down. Reinstall the (BL-KIT) pc back on the mounting plate. Next, you will utilize the ball lift motor cable, hand dryer cable and the two low voltage 24 VAC wires from the machine. Start by installing your ball lift motor cable to the (BL-KIT). The hand dryer output cable will splice into one side of the switch wire and the other to the output of the (BL-KIT). The input connection to the (BL-KIT) will come from other side of the switches high voltage. View the schematic to help wire up all the connections to the (BL-KIT). Finally, hook up the 24 VAC low voltage wires to the (BL-KIT) via the quick disconnect bullet connectors.

For repair visit: www.bowl-tronics.com/service

Fill out our service request form and ship to the address that is shown.

Notes:

Ball Lift Motor Control Kit (BL-KIT)

BALL LIFT MOTOR CONTROL CHASSIS 120 VAC INPUT

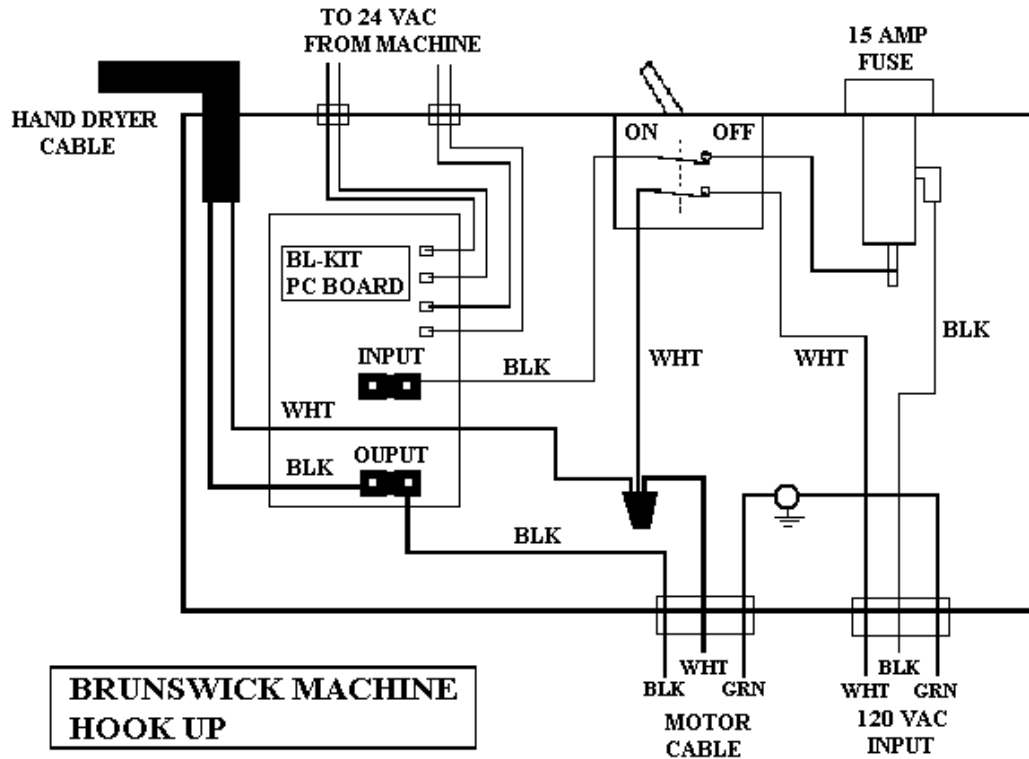

BALL LIFT MOTOR CONTROL CHASSIS 220 VAC INPUT

