

Bowl-Tronics Enterprises Incorporated

Address: 1115 Sherwood Ave.
Elgin IL. 60120
Website: www.bowl-tronics.com
E-mail: rick@bowl-tronics.com

Phone: 847-741-4500

Commander Series 1Ball Lift Motor Control Box AMF (BTC-S1/AMF/C90)

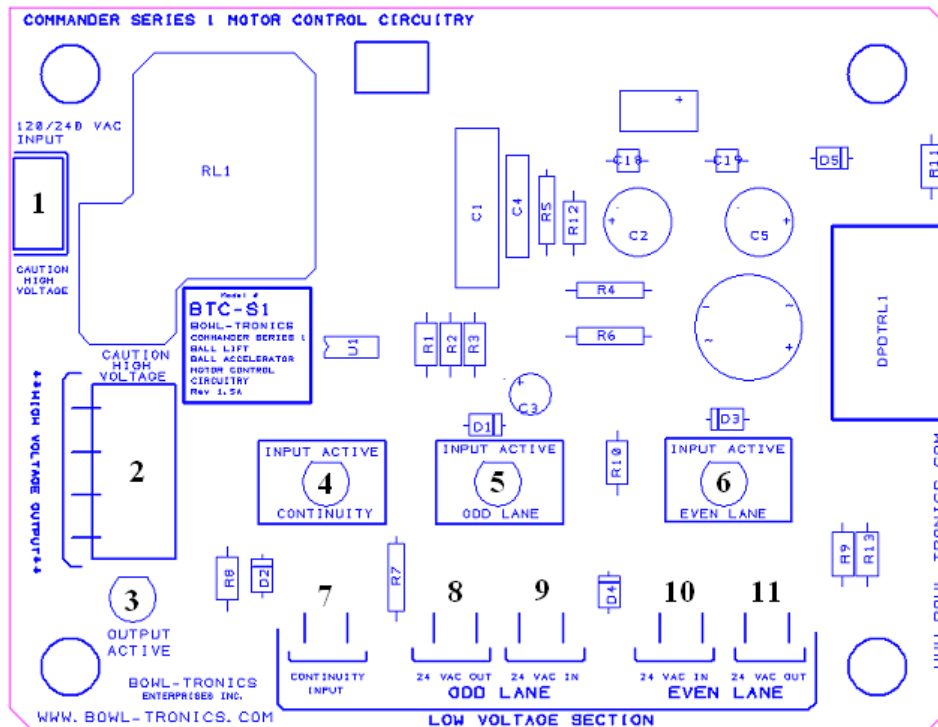

PC Board Layout Description Table:

1. High Voltage Input
2. High Voltage Output (Motor's)
3. Output Active LED (When Motor is running LED will be lit)
4. Input Active LED (AMF machine is running LED will be lit)
5. (Not used)
6. (Not used)
7. Continuity Input (AMF 82-70 and 82-90)
8. (Not used)
9. (Not used)
- 10.(Not used)
- 11.(Not used)

Ball Lift Motor Control Box Theory

This ball lift motor control box is designed to replace the existing AMF ball lift box or similar ball lift box. On the inside cover of the (BTC-S1/AMF/C90) there will be a schematic on how to wire the (BTC-S1/AMF/C90). It will also be included in this manual. Point closure from the AMF machine turns on the solid-state control circuit, this closes the circuit to start your ball lift and hand dryer motor running. *(Note!! On some AMF ball lifts such as the C-90 they use what is called an interlock switch this option is explained below.)*

Installation Instructions

Remember to remove power before performing any installation!!

First, start by removing the old ball lift box. Next, you will utilize the main power cable, ball lift motor cable, hand dryer cable, interlock switch cable and the control wire from the machines. Start by installing your main power connection to the new (BTC-S1/AMF/C90) box. Next, install the ball lift motor cable to the (BTC-S1/AMF/C90) box. The hand dryer output will have a 5 ft black SJOW cable or a 3/8 cable clamp. The SJOW cable will splice into your hand dryer motor and with the 3/8 cable clamp you supply the cable. Install the interlock switch cable to the (BTC-S1/AMF/C90) box. View the schematic to help wire up all the connections to the (BTC-S1/AMF/C90) box. Finally, hook up the control wires coming from the machines to the (BTC-S1/AMF/C90) box via the quick disconnect connectors.

For repair visit: www.bowl-tronics.com/service

Fill out our service request form and ship to the address that is shown.

Notes:

Ball Lift Motor Control Box AMF Schematic

BALL LIFT MOTOR CONTROL CHASSIS 120 VAC INPUT

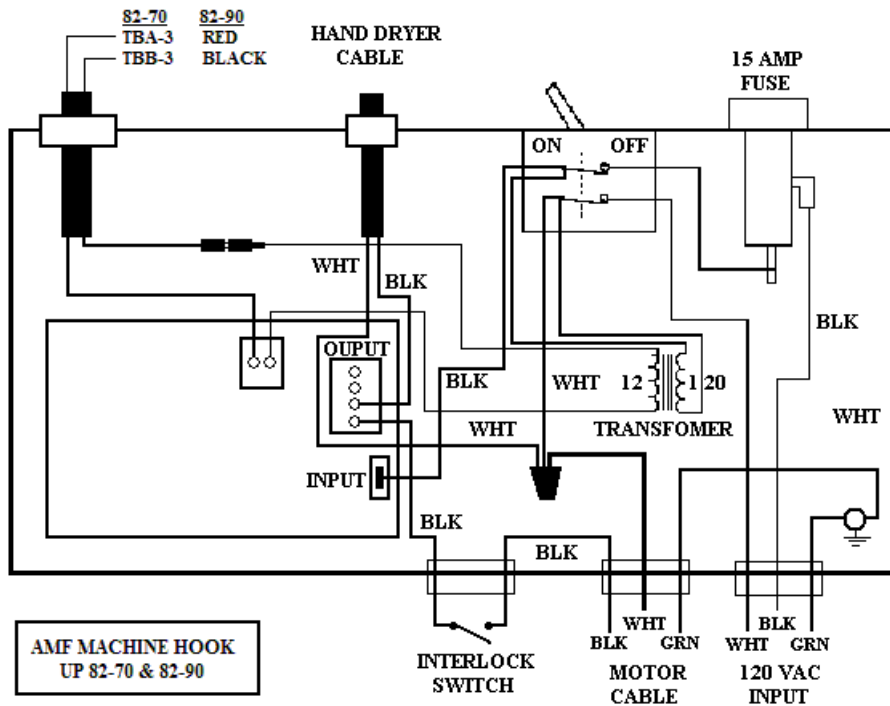

BALL LIFT MOTOR CONTROL CHASSIS 220 VAC INPUT

