

Bowl-Tronics Enterprises Incorporated

Address: 1115 Sherwood Ave

Elgin IL. 60120

Web site: www.bowl-tronics.com

E-mail: rick@bowl-tronics.com

Phone: 847-741-4500

◆ Model: MC-T-4M Infrared Triggering Unit ◆

Theory of Operation

The MC-T-4M unit consists of three main parts. The Main Circuit Board (PCM60HZ), Relay Circuit Board (PCRDC, PCRAC or PCR), and Transceiver (TC-KB60HZ, TC-SUB60HZ, TC-SUR60HZ). When a ball breaks the infrared beam the Transceiver sends a signal to the Main Circuit Board telling it a ball has passed. After processing the signal the Main Circuit Board will, after an adjustable amount of time, tell the relay card to cycle the machine.

Main Circuit Board (PCM60HZ)

This card performs all of the detection, triggering, and delay functions. The Main Circuit Board has two adjustable thumbwheel potentiometers located on the lower left and upper right corners of the circuit board. These control the amount of time between the ball breaking the infrared beam and when the machine is cycled. Turn the wheel in towards the center of the card for less delay or out towards the edge for more delay. The delay time can be adjusted from 0 to 6 seconds.

Relay Circuit Board (PCR)

This circuit board, which is the smaller of the two inside the MC-T-4M unit, performs the actual triggering of the machine. It is basically just a pair of relays that the Main Circuit Board tells to close, thus triggering your machine. There are three different kinds of relay cards. The exact model you receive will depend on the type of machine you are installing your units on.

- PCRDC This card is used on Brunswick A-2 machines and uses transistors for the triggering
- PCRAC This card is used on Brunswick A machines and uses Triacs for the triggering
- PCR This card is used on all AMF and BRC machines and uses relays for the triggering

Transceiver (TC-KB60HZ, TC-SUB60HZ or TC-SUR60HZ)

The Transceiver contains the phototransistors and Infrared Emitting Diodes. When mounted on the kickback or capping the Transceiver projects a beam of infrared light across the lane which is reflected back by the reflector. When a ball breaks this beam the Transceiver sends a signal to the Main Circuit Board letting it know a ball has passed the beam.

Block Out Switches (optional)

The block out switches, which are only used on Brunswick machines, are micro switches that mount on the 4 to 1 shaft of the gear box. When the machine cycles the Block out Switch closes, effectively disabling the MC-T-4M unit from triggering the Machine a second time. This is very useful when the Transceiver is mounted behind the sweep. When the sweep breaks the infrared beam the machine is already in operation so any signal the Main Circuit Board receives is ignored.

◆ Model: MC-T-4M Infrared Triggering Diagram ◆

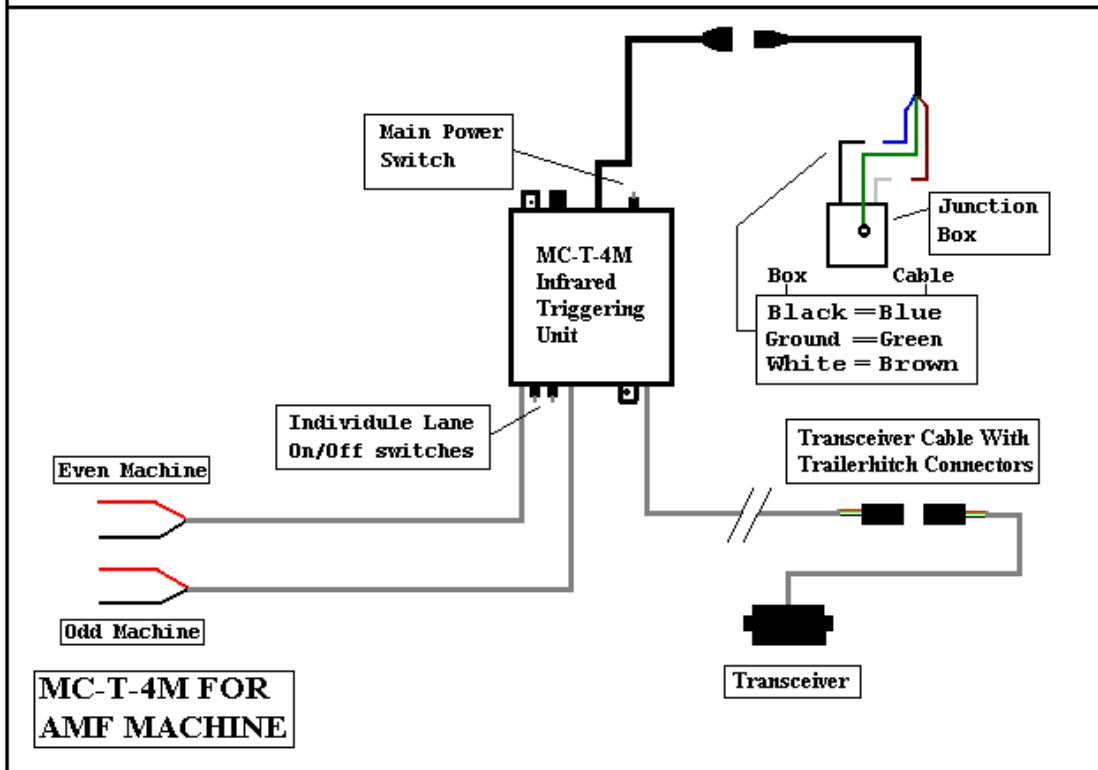
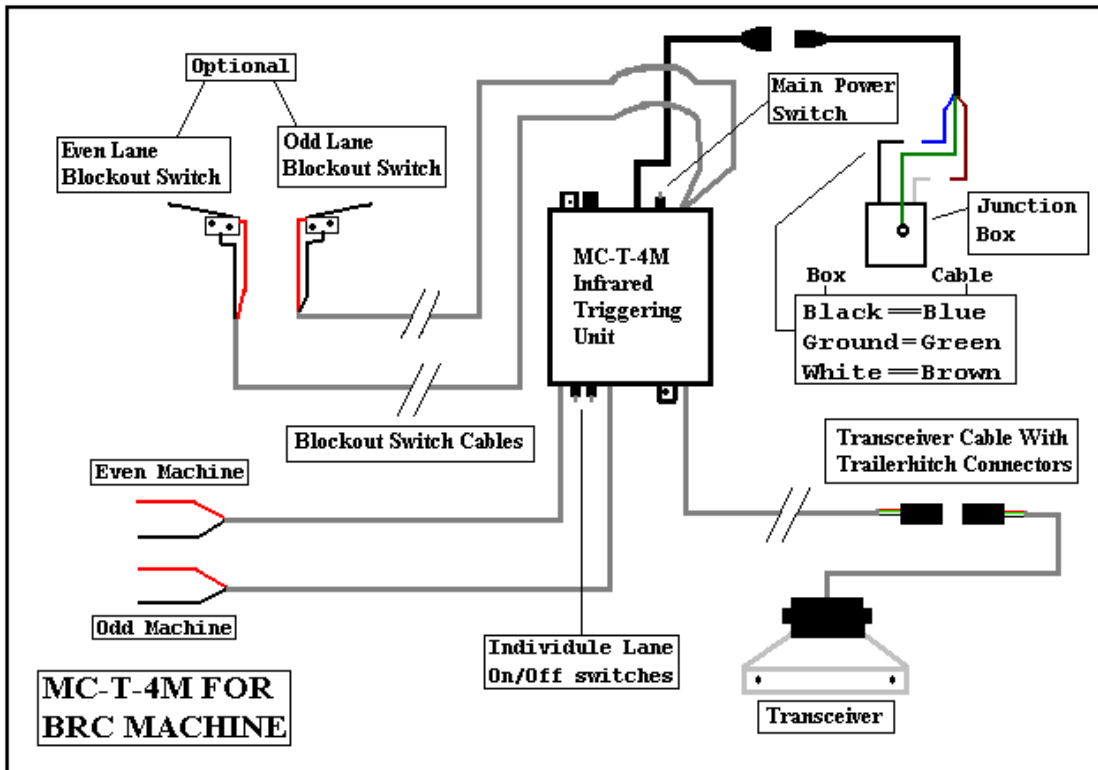

◆ Installation Instructions ◆

Before Performing Any Installation Make Sure That Power Is Removed From the Machine By Unplugging The Power Cord From The Electrical Chassis!!

Mounting the MC-T-4M Unit

The MC-T-4M Triggering Unit mounts on the curtain wall, between the pair of machines, just above the masking unit. Please refer to the installation guide on page two when installing your units. After the MC-T-4M unit is mounted on the curtain wall consult the instructions for your particular machine.

Brunswick Machine Installation

The Model A-2 Machine

Once your MC-T-4M unit is mounted on the curtain wall run the two output cables to each machines electrical control chassis. One output cable will be marked “L”, this is for the left or odd machine (1, 3, 5, etc.), the other output cable will run to the right or even machine (2, 4, 6, etc.). Run each output cable to the time delay module inside your electrical chassis. The red wire will connect to terminal #16 on your time delay module using the dual tab connector supplied with your unit. The black wire will connect to terminal #18 on your time delay module, also using the dual tab connector. Leave the wires that are already connected to the time delay module. *Note!! You must leave your rake trigger switch connected to the time delay module. If you don't have a rake trigger switch, hook the red wire to terminal #16 and your black wire to terminal #17.*

Mount the Transceiver on the kickback or capping (see page # 9 illustrations) and the reflector straight across from it. Although the Transceiver emits a wide infra red beam, try to make it point as straight as possible at the reflector. If the Transceiver is pitched up or down, this will affect the operation of the unit much more than if it is pointed to the left or right of the reflector. Also, try to mount all Transceivers and reflectors in a straight line all the way across your bowling center. Mounting everything straight and level can solve many problems in the future. A string run across the bowling center can be an easy guide for mounting Transceivers and reflectors. The Transceiver will have a white trailer hitch connector which plugs into the corresponding trailer hitch connector from the MC-T-4M unit.

If your MC-T-4M unit has Block out Switches mount them on the 4 to 1 (see page #8, illustration #1). The two wire cable from the Block out Switches each run to the MC-T-4M unit. Make sure the cable marked “L” is on the odd numbered machine.

You can now plug in the power. The cable from the MC-T-4M unit plugs into 120 volt outlet on the curtain wall.

The Model A Machine

Once your MC-T-4M unit is mounted on the curtain wall run the two output cables to each machines electrical control chassis. One output cable will be marked “L”, this is for the left or odd machine (1, 3, 5, etc.), the other output cable will run to the right or even machine (2, 4, 6, etc.). Connect the red wire to terminal #1 on the low voltage terminal strip and the black wire to terminal #11, also on the low voltage terminal strip.

Mount the Transceiver on the kickback or capping (see page #9 illustrations) and the reflector straight across from it. Although the Transceiver emits a wide infra red beam, try to make it point as straight as possible at the reflector. If the Transceiver is pitched up or down, this will affect the operation of the unit much more than if it is pointed to the left or right of the reflector. Also, try to mount all Transceivers and reflectors in a straight line all the way across your bowling center. Mounting everything straight and level can solve many problems in the future. A string run across the bowling center can be an easy guide for mounting Transceivers and reflectors. The Transceiver will have a white trailer hitch connector which plugs into the corresponding trailer hitch connector from the MC-T-4M unit.

If your MC-T-4M unit has Block out Switches mount them on the 4 to 1 (see page #8, illustration #1). The two wire cable from the Block out Switches each run to the MC-T-4M unit. Make sure the cable marked “L” is on the odd numbered machine.

You can now plug in the power. The cable from the MC-T-4M unit plugs into 120 volt outlet on the curtain wall.

It is recommended that the cycle solenoid on the A machine be modified so it will not pull so hard on the trip link. This can be accomplished by placing a stop bracket in front of the plunger (see page #8, illustration #2). Drill a hole in the solenoid mounting bracket in front of the plunger. Mount the stop bracket and slide the plunger into the solenoid until it just starts to pull on the trip latch. Slide the stop bracket up to the plunger and tighten it down. This method keeps the plunger from coming all the way out. With the plunger’s travel distance cut down it won’t pull so hard, cutting down on wear and tear on both the solenoid and the trip latch. The reason for this modification is that the cycle solenoid was not engineered to withstand energizing every cycle. This modification will add many years to the life of your cycle solenoid.

(Note!!!! If installing a Bowl-Tronics 24 VAC solenoid assembly instead of the BRC (A) high voltage solenoid follow these directions.) First, remove the high voltage solenoid and replace with the new 24 VAC solenoid w/bracket. Second, feed the new 2 conductor SJOW cable into the chassis and hook one wire to terminal #9 and the other wire to terminal #11.

AMF Machine Installation

Installation for all AMF Machines

Once your M-4 unit is mounted on the curtain wall run the two output cables to each machines TBA or AMC box. One output cable will be marked “L”, this is for the left or odd machine (1, 3, 5, etc.), the other output cable will run to the right or even machine (2, 4, 6, etc.). Run each output cable to the tenth frame button inside the TBA or AMC box. The two wire output cables connect in parallel with the tenth frame reset button. The colors do not matter as this is just point closure.

Mount the Transceiver on the kickback or capping (see page #9 illustrations) and the reflector straight across from it. Although the Transceiver emits a wide infra red beam, try to make it point as straight as possible at the reflector. If the Transceiver is pitched up or down, this will affect the operation of the unit much more than if it is pointed to the left or right of the reflector. Also, try to mount all Transceivers and reflectors in a straight line all the way across your bowling center. Mounting everything straight and level can solve many problems in the future. A string run across the bowling center can be an easy guide for mounting Transceivers and reflectors. The Transceiver will have a white trailer hitch connector which plugs into the corresponding trailer hitch connector from the M-4 unit.

You can now plug in the power. The cable from the MC-T-4M unit plugs into 120 volt outlet on the curtain wall.

(Bottom intentionally left blank)

◆ Troubleshooting Guide ◆

Troubleshooting the MC-T-4M Unit

If a problem arises with your MC-T-4M unit the easiest way to find the problematic part is to use the substitution method. From a unit that you know to work properly try swapping each component one at a time until the unit works. So if your unit is malfunctioning and you replace the Transceiver and the unit works again you know that the Transceiver is at fault and can be sent back to us for service. The same holds true for each individual component (Main Circuit Board, Relay Circuit Board, Transceiver, Block out Switches) If you replaced each component and the unit still does not operate the most likely cause is that it is wired improperly.

You Experience Random Triggering On Either or Both Lanes

- Double check your wiring
- Make sure Transceiver is properly aligned (Purchase a TATPC60HZ for proper alignment)
- Check that the reflector is clean
- Try swapping components that you know to work

Mismatched Components

If your center has MC-T-4M Triggering Units installed prior to 1996 they may have a different type of PCM and Transceiver that is not compatible with the new system. The easiest way to tell is to look at the PCM where it plugs into the connector. The older type board has a large resistor that resembles a cement block near the edge where it plugs into the connector, the newer board does not. The new type Transceiver will have five wires attached to the trailer hitch connector while the older type will have eight attached to it.

If you have multiple types of systems make sure that the new type PCM is used in conjunction with the new type Transceivers. The old type PCM must be used with the Old type Transceiver.

The most common type of malfunction you will find if the older and newer types are used in the same unit is that one side will trigger constantly while the other side will work fine. BOWL-TRONICS still manufactures and repairs both types of boards and Transceivers so you are not stuck if you do have a mismatch although we do recommend upgrading to the newer system. The actual unit that everything plugs into is still the same.

Basic Troubleshooting

Visually inspect your unit to be sure that all proper connections are made. Many problems can be solved by changing the Transceiver and making sure that it is lined up properly. The reflectors also play a large part. If the reflector is dirty it will fail to reflect the infrared beam back to the Transceiver. Also, make sure that the wiring in the machine is correct (especially in Brunswick machines)

As with all electronic goods, parts do fail. At Bowl-Tronics we buy only the highest quality electronic parts available to us. Your unit should give you many years of reliable service. If in the event your unit does fail to operate correctly, you should call Bowl-Tronics at the number listed on the next page.

◆ Brunswick Illustrations ◆

4 To 1 Block out Switch Mounting On Brunswick Machine

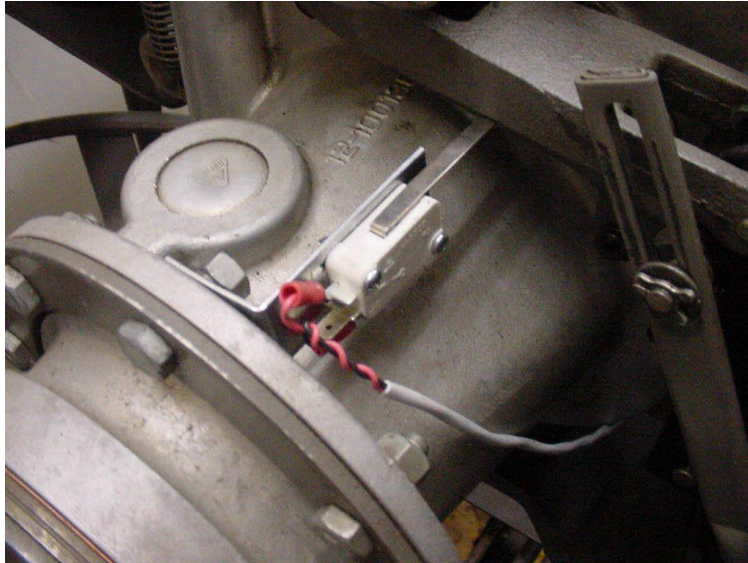
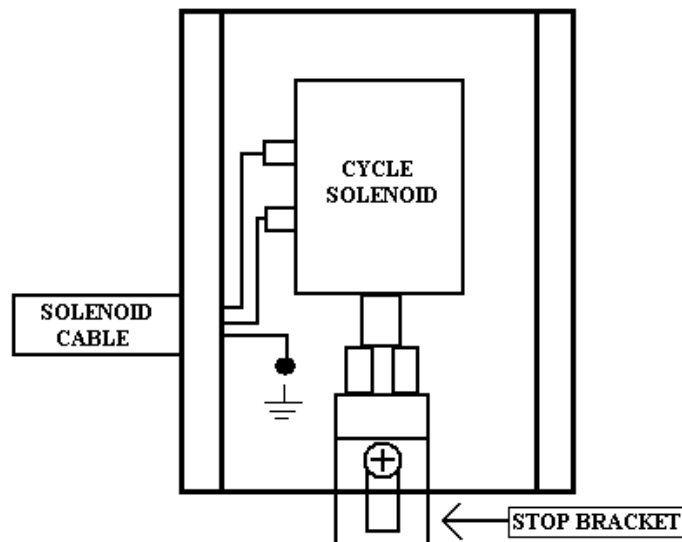

ILLUSTRATION SHOWS LEVER IS DEPRESSED AT 0 DEGREES AT IDLE

Stop Bracket on Brunswick “A” Cycle Solenoid



STOP BRACKET REDUCES THE PLUNGER TRAVEL PREVENTING IT FROM PULLING SO HARD ON THE CLUTCH TRIP LEVER

MOUNT TRANSCEIVER LEVEL AND STRAIGHT ACROSS FROM REFLECTORS

